

INSTRUCTIONS
AND
PARTS LIST

SHAW-BOX[®]

MOTOR DRIVEN
TRAVERSE ARRANGEMENT

For 5 thru 10 Ton
Series 700 Deck Mounted
Wire Rope Electric Hoists

LIFTTECH[®] 

LIFT-TECH INTERNATIONAL
Division of Columbus McKinnon
MUSKEGON, MICHIGAN 49443

SHAW-BOX



12578

Figure A.

THE INFORMATION CONTAINED IN THIS MANUAL IS FOR INFORMATIONAL PURPOSES ONLY AND LIFT-TECH INTERNATIONAL, INC. DOES NOT WARRANT OR OTHERWISE GUARANTEE (IMPLIEDLY OR EXPRESSLY) ANYTHING OTHER THAN THE COMPONENTS THAT LIFT-TECH MANUFACTURES AND ASSUMES NO LEGAL RESPONSIBILITY (INCLUDING, BUT NOT LIMITED TO CONSEQUENTIAL DAMAGES) FOR INFORMATION CONTAINED IN THIS MANUAL.

TO BUILD MOTOR DRIVEN TRAVERSE ARRANGEMENT

GENERAL

The following items are required for assembly of the traverse arrangement: One Series 700 deck mounted wire rope electric hoist, one driver truck, one trailer truck, one gear box and one motor, an optional brake may be furnished. The builder will have to furnish the material required for mounting the electrical enclosure and, if required, material for mounting a resistor. The resistor is required for three speed hoists only.

The builder must also furnish a means of supplying power to the traverse. This will be collectors, festooned cable or cable reel.

MOUNTING HOIST

Although some traverse trucks have more than one set of mounting holes for the hoist, the specified hoist will match only one set of holes.

Place trucks, with mounting pads up, on supports that allow the wheels to hang free. Orient the trucks as shown in Figure A. With the gear case note (stenciled on trucks) at the same end of both trucks, the driver truck is on the right as the traverse is viewed from the gear case side.

Lower the hoist, with the gear case side properly oriented to the notes on the trucks, onto the trucks, adjusting the distance between the trucks to match the hoist mounting

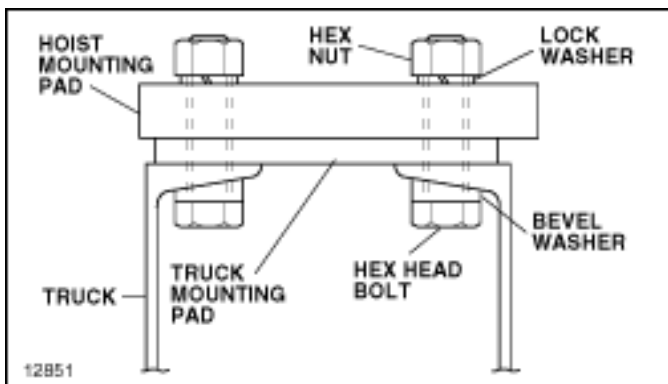

Figure B.

holes. Bolt hoist down with hardware furnished with trucks. See Figure B.

MOUNTING CONTROL PANEL

Refer to Figure C. If hoist is single or two speed, builder need supply only item A and four bolts, lockwashers and nuts (item H, J and K) for securing control panel.

For a three speed hoist, all the material listed in Figure C is required. The additional material is required for the secondary resistor.

Using first quality steel, free of rust and mill scale, fabricate the required material and assemble on the trailer truck as shown on Figure C. It is strongly recommended that any welding be done by qualified welders.

The control module for traverse control is mounted in the control panel.

BALLAST RESISTOR MOUNTING – OPTIONAL

The ballast resistor for the traverse is an optional item. If ordered, all material listed in Figure D is required for mounting and must be furnished by the builder.

Using first quality steel, free of rust and mill scale, fabricate the required material, and then assemble the material on the traverse gear case unit as shown in Figure D.

ELECTRICAL

The traverse wiring diagrams are shown in 113533-78.

ITEM	QUAN.	DESCRIPTION	MATERIAL
A	2	L3 x 3 x 1/4 x 20 Long	ASTM A 36
B	2	L3 x 3 x 1/4 x 16-3/4 Long	ASTM A 36
C	1	Bent Sheet 16 Ga. x 18-3/4 x 20-1/2 Long	ASTM A 569
D	2	Strip 16 Ga. x 1-1/16 x 16-5/8 Long	ASTM A 569
E	1	16 Ga. x 16-3/4 x 20-1/2 Long	*
F	2	16 Ga. x 5-3/4 x 15-3/4 Long	*
G	2	16 Ga. x 5-3/4 x 19-1/2 Long	*
H	8	3/8 - 16 x 1" Long Hex Head Bolt	ASTM A 307
J	12	3/8 - 16 Hex Nut	ASTM A 307
K	12	3/8 Lockwasher	
L	4	3/8 - 16 x 3/4" Long Hex Head Bolt	ASTM A 307

* Standard Carbon Perforated Sheet Steel

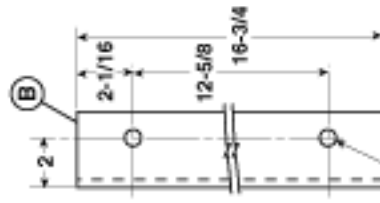
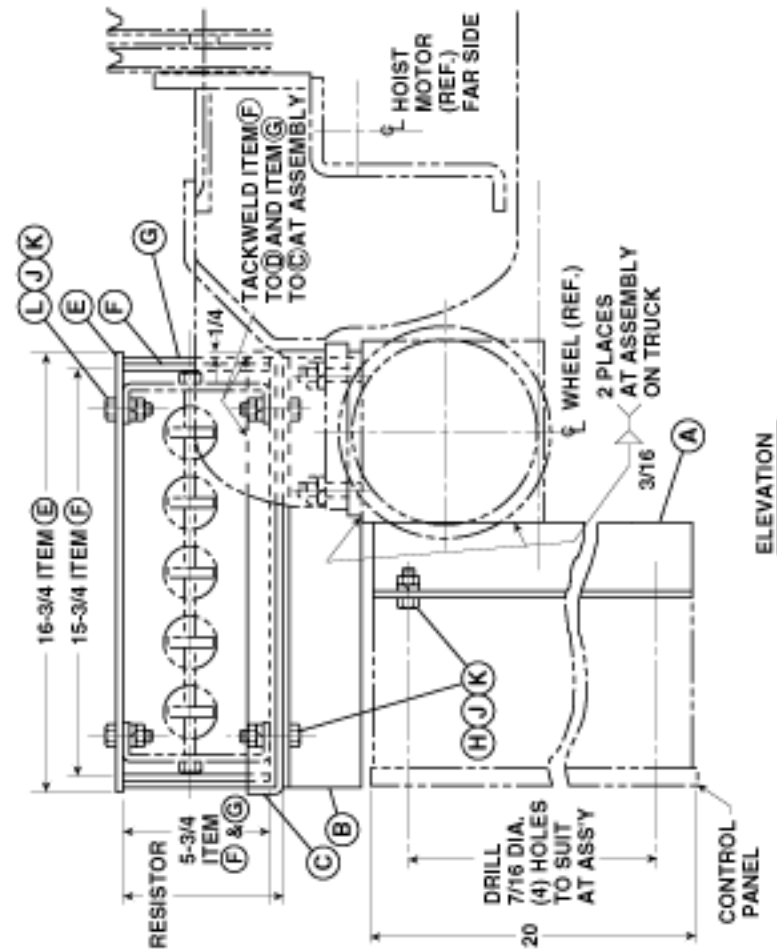

DRILL 7/16" DIA.
(2) HOLES

RESISTOR MOUNTING

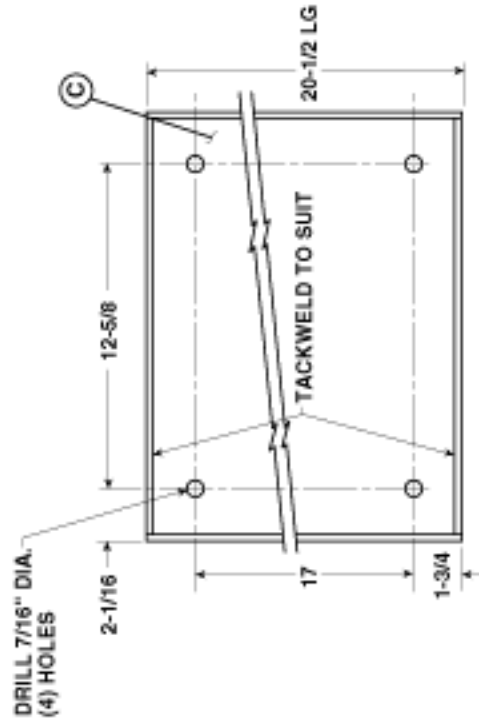

DRILL 7/16" DIA.
(4) HOLES

16 GA. (.0598) 16-5/8 ITEM D 1-1/16

RESISTOR DRIP TRAY

ELEVATION

12506

Figure C. Electrical Enclosure and Resistor Mounting Arrangement

ITEM	QUAN.	DESCRIPTION	MATERIAL
A	1	L3 x 3 x 1/4 x 6 Long	ASTM A 36
B	1	Plate 1/4 x 6 x 11-3/8 Long	M 1020
C	6	1/4 - 20 x 1" Long Hex Head Bolt	ASTM A 307
D	6	1/4 - 20 Hex Nut	ASTM A 307
E	6	1/4 Lockwasher	
F	2	3/8 - 16 x 1-1/4" Long Hex Head Bolt	ASTM A 307

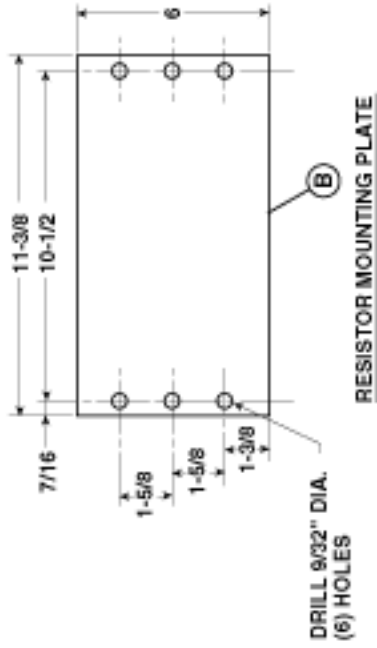
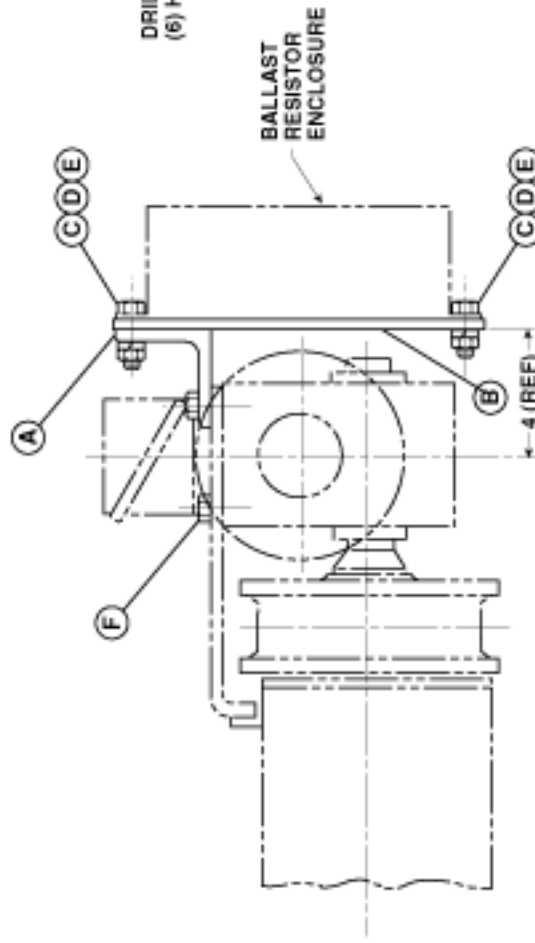

DRILL 9/32" DIA.
(6) HOLES

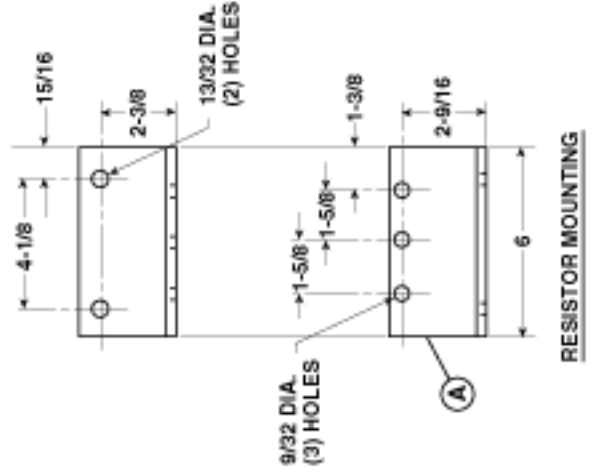

Figure D. Ballast Resistor Mounting Arrangement

INSTALLATION OF MOTOR DRIVEN TRAVERSE ARRANGEMENT

This manual contains important information to help you to operate, maintain, and service the traverse arrangement of your crane trolley. The hoist is covered in a separate manual.

We recommend that you study the contents thoroughly before putting the traverse into use. With proper installation, application of correct operating procedures, and practicing the recommended maintenance suggestions you will be assured maximum service from your traverse.

The traverses described in this manual are intended for indoor service. Traverses to be used for outdoor service require special consideration.

IMPORTANT!

When ordering replacement parts be sure to include with your order, the KEY NUMBERS, which are identified elsewhere in this manual.

Information given in this manual is subject to change without notice.

GENERAL DESCRIPTION

GENERAL: These traverses are designed to operate on parallel bridge girders with 25# ASCE rails. Motor and control are designed for 208V, 230V, 460V or 575V – 3 phase – 60 hertz power supply. The traverse is equipped with a single or two speed motor, controlled from a pendant push button station. The push button may be located on the bridge or hoist traverse unit. Traverses described herein, are built in rated loads from 5 thru 10 tons.

BASIC CONSTRUCTION: The traverse frame is of rolled steel welded construction. The frame consists of two trucks rigidly bolted to the hoist.

The traverse is driven by a motor and gear box attached to one truck. This drives the truck axle by a hollow shaft keyed to the axle.

INSTALLATION

GENERAL: Bridge girders on which these traverses will operate must be amply strong to support traverse, hoisting equipment and rated load. Traverse rails should be level and parallel within $\pm 1/4"$. Rail joints must be smooth and held firmly in alignment either by bolted splice bars or welding. Rails should be securely fastened to the bridge girders.

INSTALLING: The installation of the traverse on the crane shall be performed only by qualified installer.

For information regarding attaching, lifting and moving the loads during installation, refer to ANSI B30.2.0, Section 2-3.2 and other applicable codes.

Consult the Manufacturer for the traverse weight and other required information before attempting installation.



WARNING

Before installing traverse on bridge, lock runway conductor disconnect switch in open (power off) position.

Total weight of traverse and hoist should be checked against lifting equipment selected for erection of traverse.

Immediately after traverse is placed on the traverse rails, check wheel flange clearances to the rail. Clearance between side of rail head and inside flange of wheel will be $1/4"$ for a 25# ASCE traverse rail with wheel centered on rail.

CONNECTING TRAVERSE TO ELECTRICAL SERVICE: Traverse wiring diagrams are shown in 113533-78.



CAUTION

Verify that traverse is furnished for the same voltage, frequency and phase as the traverse power supply. Do not operate traverse until "Pre-Operation Checks" below are made.

PRE-OPERATION CHECKS: After the hoist traverse unit is connected to electrical service, the following pre-operation checks should be made before operation:

1. Check collector system for proper adjustment to maintain proper contact with conductors or check along span for possible interference if power supply is cable reel or festooned cable.
2. Make certain traverse stops have been installed and that they are correctly located.
3. Check truck axles and oil level of gear box. If lubricant is required, see LUBRICATION on page 11.
4. Inspect the traverse to make certain all bolted attachments are properly tightened and all electrical connections are secure.
5. The hoist unit should be checked as instructed in the Hoist Manufacturer's Instruction Manual. Check to make sure that traverse wheels have proper clearance to rails for freedom of operation.
6. The traverse wheels and the flange surface of crane rails on which traverse wheels roll should be free of paint to provide proper electrical ground. If the environment in which the crane will operate is such as to impair the contact between traverse wheel and crane girder, an extra conductor should be provided for grounding purposes.

NOTE: This instruction also applies to the bridge wheel and runway rail.

OPERATION

OPERATOR QUALIFICATIONS: Safe and efficient crane operation requires skill, extreme care and good judgement, alertness, concentration and knowledge of and rigid adherence to proven safety rules and practices. No person should be permitted to operate a crane or hoist:

1. who does not possess above characteristics.
2. who is not qualified or has handicaps that could adversely affect such operation.
3. who has not been properly instructed.
4. who has not been informed and does not have a thorough knowledge of all applicable safe operating practices, including those in this book as well as hitching equipment and practices.

NOTE: See applicable National, State and Local Safety Codes and regulations for additional requirements relating to Safe Operating Practices, including American National Standards ANSI B30.2.0 and ANSI B30.16 as published by American Society of Mechanical Engineers.

OPERATING RULES: Operating rules listed below are an earnest effort to encourage SAFETY and are not intended to take precedence over individual plant safety rules and regulations or rules set forth by various applicable codes.

A good operator operates his crane as smoothly as possible and knows and follows the suggested rules below for safe, efficient crane handling.

Take time to become familiar with performance and all functions of the crane including safety devices.

Hitch loads securely. This is the joint responsibility of the hitcher and the crane operator. Never lift load with loose slings or with sling hooks attached to crane hook.

If the brakes do not hold, do not operate crane. Report defect immediately to supervisor.

Never leave load hanging from crane or hoist when not attended.

Know the safe capacity of crane and chain slings, rope slings, etc. Do not make lifts above safe capacity of crane or slings.

See that the immediate area is clear before moving a load. Do not lift loads over persons.

Avoid bumping other cranes on a runway unless specifically authorized to do so. Never move or bump another crane having a warning sign displayed.

First be sure to hoist load high enough to clear all workmen and obstructions before moving bridge or trolley.

Energize each motion gradually and avoid abrupt, jerky movements of the load.

Take up slack from sling and hoisting cables before lifting load.

Yield to people in a working area; allow them time to get out of danger.

Follow operating and maintenance procedures described in manufacturer's manuals to operate and maintain bridge, traverse and hoist.

Inspect crane frequently. Be alert for unusual or erratic conditions. Be certain the crane is SAFE to operate at all times.

Repair electrical apparatus or make other major repairs only when specifically authorized to do so. Do not change fuse sizes. Never attempt to close a switch having a "DO NOT OPERATE" sign or card attached.

Stop crane, hoist or traverse under normal operating conditions before engaging limit switches. Limit switches are safety devices and should not be used as a normal operating control.

Traverse the bridge and traverse to a position directly over the load before starting to hoist. The hoisting chain or rope should be kept vertical to avoid swinging the load as the lift is started.



CAUTION

Make sure all INSTALLATION AND OPERATION CHECKS have been made before turning on power.

LEARNING THE CONTROLS: After making certain the traverse is completely and properly installed with traverse connected to power supply and all pre-operation checks made, the operator should learn the controls.

The operator should locate the runway disconnect and make sure this switch is locked open (POWER OFF). The operator should now operate the various push buttons to get the “feel” and determine that they do not bind or stick in any position. The operator should become familiar with push button location for their respective motions as well as “start” and “stop” buttons which operate the crane main line contactor. The main line contactor will shut off power to all motions.

 WARNING
If any push button binds or sticks in any position – Do not turn power on – Determine the cause of malfunction and correct before operating crane.

OPERATING THE CONTROLS (NO LOAD): Having inspected and tried the pendant push button station, the crane operator is now ready to try the crane under power.

First – Close the crane runway disconnect switch.

Second – Close the crane disconnect switch.

Third – Press the start-push button which will close the main line contactor, applying power to all control devices. The traverse is now ready for further testing.

The traverse is powered by a single or two speed motor. There is one button for each direction, labeled “Left” and “Right”. Depressing either button will cause traverse to operate.

 CAUTION
ALWAYS ALLOW TRAVERSE TO COME TO A COMPLETE STOP BEFORE CHANGING DIRECTION. ABRUPT CHANGE OF TRAVERSE DIRECTION WHILE IN MOTION, MAY CAUSE ADVERSE OPERATING CHARACTERISTICS OR DAMAGE TO TRAVERSE AND DRIVE COMPONENTS.

Fourth – Momentarily depress traverse “Left” button. Check to be certain motor runs in the proper direction. Momentarily depress “Right” button. Check direction. To reverse directions, interchange leads L1 and L2 in the traverse panel.

 WARNING
Lock crane main switch open (power off) before reversing leads.

Fifth – To check that electrical connections have been properly made, operate traverse cautiously on bridge. Watch for any obstructions or interferences between traverse and building parts. Depress “Left” button slightly – traverse will travel along bridge.

Sixth – Operate traverse from one end of bridge to the other, checking for obstructions or interferences. Proceed with CAUTION and be prepared to stop short of any obstructions. If traverse power is interrupted during traverse travel, check traverse collectors for proper contact with bridge conductors.

 WARNING
Lock main runway disconnect switch in open (power off) position before attempting to adjust cross collectors or conductors.

Seventh – After making certain that all building and structural clearances are adequate, practice going “Left” and “Right” with push button depressed. Note the stopping distance of the trolley without load.

After becoming familiar with these motions, the operator can now depress the hoist “Up” button.

 WARNING
If, when depressing hoist “Up” button, the hook should lower – STOP AT ONCE – Do not attempt to operate again. Report this condition to proper supervisor for correction with instructions furnished with your hoist manual.

Depress the “Down” button, with hook moving downward on multi-speed hoists, try to feel the steps in relation to speed increase as push button is depressed further.

Hook may be lowered until TWO FULL WRAPS of cable remain on the drum. Note position of hook and NEVER LOWER HOOK BELOW THIS POSITION. (Some hoists may have a lower limit switch which will stop hoist when this position is reached. Consult Hoist Manufacturer’s Manual.)

Depress the hoist “Up” button and slowly return the hook to near its high position. Continue to raise hook by slowly inching. CAREFULLY OBSERVE the relationship of the hook block and the bottom of the hoist frame. The hoist upper limit switch, when working properly should cause the hoist up motion to stop and/or reverse direction.

 WARNING
Do not contact or strike hoist frame with hook block. If hoist motion is not interrupted by limit switch, stop hoist by removing finger from button and/or depressing the STOP button. Do not attempt further operation until limit switch is operable. Consult Hoist Manufacturer’s Instructions.

Repeat upper limit switch test described above at full speed.



WARNING

During this test and under any other operating condition – OPERATOR SHOULD NEVER BE POSITIONED UNDER THE HOOK OR LOAD.

NOTE: Jogging is used excessively by some operators for making “inching” crane movements. **AVOID EXCESSIVE USE OF JOGGING SINCE IT MAY CAUSE PREMATURE BURNING OF CONTACT TIPS AND MOTOR OVERHEATING.**



WARNING

THIS EQUIPMENT IS NOT DESIGNED OR SUITABLE AS A POWER SOURCE FOR LIFTING OR LOWERING PERSONS.

OPERATING THE CONTROLS (WITH LOAD): Make certain hook is high enough to clear any obstructions below. Move the bridge to a position directly over the load, and operate in the following sequence:

STEP 1: Spot the traverse and hoist over the load. If control is suspended from the bridge, hand signals may be required from ONE authorized floor man at the load. Be certain load to be lifted is properly hitched and does not exceed the rated capacity of the hoist, traverse or bridge.

STEP 2: Slowly raise the hook until slack has been taken out of slings. When floor man signals and operator is satisfied load is secure in sling, he lifts the load slowly until clear. Now, hoisting speed can be increased and maintained until load is clear of all obstructions or floor man gives the signal to stop.

STEP 3: Starting slowly and increasing speed as distance permits, move the bridge toward the point where the load is to be lowered. The stopping distance will be greater than with no load on the hook.

STEP 4: Learn to judge the stopping distance of the bridge and traverse, both with light loads and full loads. This will enable you to “spot” loads with the minimum amount of jogging.

NOTE: Refer to hoist manual for complete operating instructions for hoist.

RESPONSIBILITY FOR SAFE OPERATION: Each crane operator should be held directly responsible for the safe operation of his crane. The crane operator should STOP the crane and refuse to handle loads when:

1. there is any doubt as to SAFETY;
2. any unusual vibrations or sounds are noticed before or when starting the lift or traverse motions;
3. there are arguments or disagreements with floor man or hitches;
4. he feels ill or is not alert.

INSPECTION

The crane should be inspected at the beginning of each shift. All functional mechanisms should be in good working order. Check limit switches, brakes, electrical equipment, and other SAFETY devices. Check crane operation without load. Any unusual sounds, vibrations, anything wrong or apparently wrong should be reported to the operators’ supervisor immediately. Inspect hoist as recommended in manufacture’s hoist manual.



WARNING

Do not operate a crane, hoist or traverse having unusual vibrations, sounds, warnings or with anything wrong or apparently wrong. Danger may be present that the crane operator cannot see. Determine and correct cause of unusual conditions and make certain the crane can be operated SAFELY.

Complete inspection of the crane is to be performed at least every six months and more frequently when conditions require. Inspect areas listed below and any other area which may be adversely affected due to activity, severity of service and crane environment that could cause unsafe crane operation.



WARNING

Always lock main switch in open (power off) position before inspection.

Items to be inspected include, but are not limited to:

1. All functional operating mechanisms for maladjustment interfering with crane operation.
2. Operating parts for excessive wear.
3. All safety devices for malfunction.
4. All connections and mountings for loose bolts, nuts or other fasteners for tightness.
5. All structural members for deformation, cracks, corrosion.
6. All electrical apparatus, including control contactors, limit switches, push button stations for signs of pitted contact points, wear or deteriorations.
7. All hoists and traverses installed on the crane in accordance with manufacture’s recommendations.

Written, dated and signed inspection reports should be maintained on all critical items (such as safety devices, brakes, hooks, ropes, chains, etc.). All worn, damaged or malfunctioning parts should be repaired or replaced to maintain a SAFE operating crane. Warning labels affixed to the crane, hoist or traverse should be kept clean and visible at all times. Warning labels should be replaced if loose or illegible. A typical inspection Schedule and Maintenance Report Form is shown on Page 10.

INSPECTION SCHEDULE AND MAINTENANCE REPORT

CRANE SERIAL NO. (MFGRS) _____ CUSTOMER CRANE IDENTITY NO. _____
 RATED LOAD _____ LOCATION IN PLANT _____
 TYPE _____ THIS INSPECTION IS MONTHLY ANNUAL
 VOLTAGE _____ SEMI-ANNUAL
 INSPECTED BY: _____ DATE _____

COMPONENT, UNIT OR PART and location		* Recommended Inspection Interval			CONDITION (Check column best indicating condition when part or unit is inspected. Use note column to the right if condition is not listed below.)						CORRECTIVE ACTION NOTES	
		MONTHLY	SEMI-ANNUAL	ANNUAL	GOOD	ADJUSTMENT REQUIRED	REPAIR REQUIRED (Loose Parts or Wires)	REPLACEMENT REQUIRED (Worn or Damaged)	LUBRICATION REQUIRED (Low Oil or Grease, Rust or Corrosion)	CLEANING OR PAINTING REQUIRED		
BRIDGE	Motor	<input type="radio"/>									(Indicate corrective action taken during inspection and note date. For corrective action to be done after inspection, a designated person must determine that the existing deficiency does not constitute a safety hazard before allowing unit to operate. When corrective action is completed, describe and note date in this column.)	DATE
	Gears & Bearings	<input type="radio"/>										
	Wheels	<input type="radio"/>										
	Trucks		<input type="radio"/>									
	Girders & Connections			<input type="radio"/>								
	Footwalk & Handrail			<input type="radio"/>								
HOIST	Motor	<input type="radio"/>										
	Motor Brake	<input type="radio"/>										
	Mechanical Load Brake	<input type="radio"/>										
	Overload Clutch	<input type="radio"/>										
	Couplings	<input type="radio"/>										
	Gear, Shafts & Bearings	<input type="radio"/>										
	Upper Block	<input type="radio"/>										
	Lower Block	<input type="radio"/>										
	Hook & Throat Opening	<input checked="" type="radio"/>		X							Record Hook Throat Opening	
	Hoist Rope	<input checked="" type="radio"/>										
	Rope Drum		<input type="radio"/>									
	Guards		<input type="radio"/>									
CONTROL PANELS AND PUSH BUTTON	Limit Switch	<input type="radio"/>										
	Bridge Panel	<input type="radio"/>										
	Trolley Panel	<input type="radio"/>										
	Hoist Panel	<input type="radio"/>										
	Pushbutton		<input type="radio"/>									
	Wiring		<input type="radio"/>									
TROLLEY	Motor	<input type="radio"/>										
	Brake (when so equipped)	<input type="radio"/>										
	Couplings	<input type="radio"/>										
	Gear, Shafts & Bearings	<input type="radio"/>										
	Frame			<input type="radio"/>								
	Wheels		<input type="radio"/>									
	Bumpers		<input type="radio"/>									
	Guards		<input type="radio"/>									
	Conductors	<input type="radio"/>										
	Collectors	<input type="radio"/>										
RUNWAYS	Monorail Joints		<input type="radio"/>									
	Monorail		<input type="radio"/>									
	Main Conductors	<input type="radio"/>										
	Main Collectors	<input type="radio"/>										
MISC.	General Condition		<input type="radio"/>									
	Load Attachment Chains	<input checked="" type="radio"/>										
	Rope Slings & Connections	<input checked="" type="radio"/>										
	Change Gearcase Lub.			<input type="radio"/>								
	Grounding Faults		<input type="radio"/>									

* See text for DAILY & WEEKLY REQUIREMENTS. ● SIGNED & DATED REPORT REQUIRED – OSHA.
 ○ INSPECTION INTERVAL. X MAGNETIC PARTICLE OR EQUIVALENT EXAMINATION REQUIRED.

Typical Inspection Schedule and Maintenance Report form.

User must adjust inspection interval and components to suit his individual conditions and usage.

12382A

MAINTENANCE

GENERAL: Maintenance services required on traverses are, for the most part, simple periodic inspections and adjustments. Procedures for lubrication, routine adjustments and replacement of parts, if required, are described in the following paragraphs.

LUBRICATION: Motor bearings are lubricated for the life of the bearing and require no additional lubrication.

Axle bearings are lubricated for the life of the bearing and require no additional lubrication.

The gear box attached to the motor requires gear case oil having a viscosity at 210½F of 125-150 SSU, viscosity index at 90 and a pour point of 25½F (AGMA #7 Compound) at an ambient temperature of 50½ to 125½F. For ambient temperatures outside this range, refer to the Manufacturer for recommendations.

General oiling should be performed every three months to prevent rusting and provide limited lubrication for points not having lubrication fittings nor considered normal wear points. Pins, levers, rods, hinges and other linkages and moving parts, where rusting could occur and interfere with normal operation, should be oiled with a few drops of oil. (Examples include, collector pins and linkage, limit switch linkage, cable carriers, etc. Also see instructions furnished with hoist.)

The frequency of oil changes in the gearhead unit and axle bearing lubrication is dependent on crane usage. The user should establish a lubrication interval based on individual conditions of usage and environment (including airborne dirt, chemical dust, moisture, etc.), but this interval should never exceed six months. Also, drain and refill gear box after first 100 hours of operation.

For hoist lubrication instructions refer to Hoist Manufacturer's Service Manual.

WHEEL REMOVAL

(Refer to parts illustration, Figure 2.)

To remove wheels, follow steps 1 through 6 listed below:

1. Remove any load from hook.

 WARNING
Make sure that traverse is adequately supported so that it cannot drop when wheel is removed. Also lock main runway disconnect switch in open (power off) position when working on wheels adjacent to runway conductors.

2. Remove load from wheel axle. This can be accomplished by jacking a small distance, just enough to clear the wheel flanges.
3. Wheel (Ref. No. 2) is held in position by retaining ring

(Ref. No. 1), in a groove in the axle. Remove retaining ring.

4. Wheel is now free. Remove by sliding horizontally off axle, maintaining a secure hold so that wheel does not fall.

5. Remove key (Ref. No. 4).

6. Replace wheels in reverse procedure of disassembly. Wheel at motor may be removed by using the above procedure after the motor and gear box have been removed.

AXLE REMOVAL

(Refer to parts illustration, Figure 2.)

To remove axle, follow steps 1 through 4 listed below:

1. Remove both wheels on truck as described above.
2. One side of truck has a retaining ring (Ref. No. 7), securing the axle bearing (Ref. No. 3). The axle (Ref. No. 5) may be removed by pushing axle toward opposite side of truck. Maintain a secure hold on the axle so that it does not fall.
3. If required, retaining ring may also be removed allowing removal of both bearings.
4. Replace axle in reverse procedure of disassembly.

It is recommended that bearings be replaced whenever replacing wheels or axles.

The axle at the motor may be removed by using the above procedure after the motor and gear box have been removed.

GEAR BOX REMOVAL

(Refer to parts illustration, Figure 1.)

 WARNING
Main runway disconnect switch should be locked open (power off) before working on gearmotor.

To remove gear box:

1. Disconnect wiring and conduit at conduit box on motor.
2. Remove the four bolts and lockwashers holding the top of the gear box to the mounting plate on the driver truck.
3. Slide gear box and motor off axle extension taking care not to drop it.
4. Remove key (Ref. No. 2).
5. Remove four bolts and lockwashers (Ref. Nos. 3 and 4) to separate motor from gear box.
6. Reassemble in reverse.

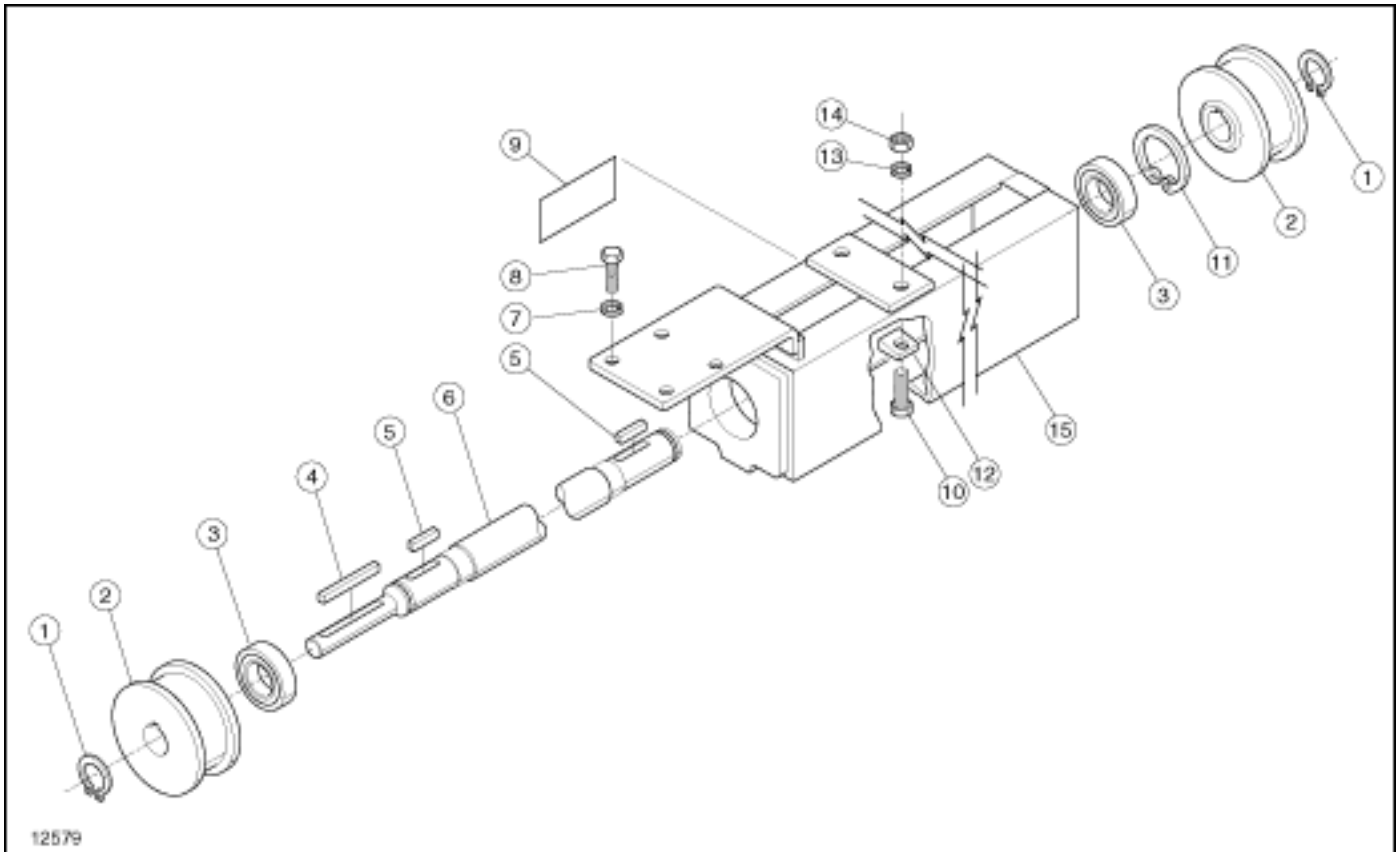

Figure 1. Driver Truck.

Ref. No.	Key Number	Description	Qty. Req'd
1	CBH-1101	Ring – Retaining	2
2	CBH-1102	Wheel	2
3	CBH-1103	Bearing – Ball	2
4	CBH-1104	Key – Parallel	1
5	CBH-1105	Key – Parallel (3/8 x 3/8 x 2-1/4)	2
6		Axle	1
	CBH-1106	48" Gage	
	CBH-1107	66" Gage	
	CBH-1108	78" Gage	
7	CBH-1109	Lockwasher (3/8)	4
8	CBH-1110	Bolt – Hex Head (3/8-16 x 1)	4
9	CBH-1111	Nameplate	1
10	CBH-1112	Bolt – Hex Head (1/2-13 x 2-3/4)	4
11	CBH-1113	Ring – Retaining	1
12	CBH-1114	Washer – Bevel (1/2)	4
13	CBH-1115	Lockwasher (1/2)	4
14	CBH-1116	Nut – Hex (1/2-13)	4
15		Assembly – Trolley Beam	1
	CBH-1117	48" Gage	
	CBH-1118	66" Gage	
	CBH-1119	78" Gage	

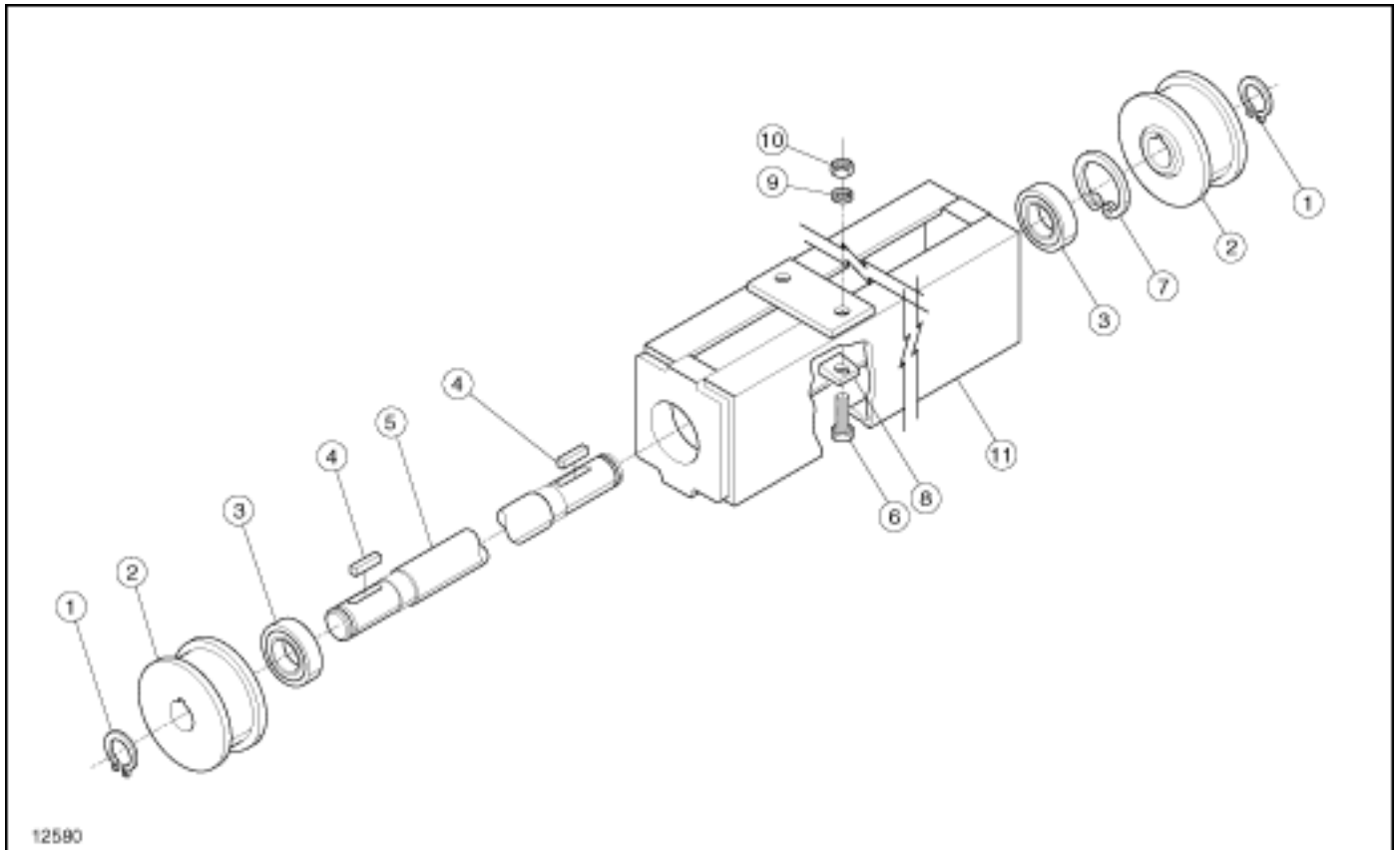

Figure 2. Trailer Truck.

Ref. No.	Key Number	Description	Qty. Req'd
1	CBH-1201	Ring – Retaining	2
2	CBH-1202	Wheel	2
3	CBH-1203	Bearing – Ball	2
4	CBH-1204	Key – Parallel (3/8 x 3/8 x 2-1/4)	2
5	CBH-1205	48" Gage	1
	CBH-1206	66" Gage	
	CBH-1207	78" Gage	
6	CBH-1208	Bolt – Hex Head (1/2-13 x 2-3/4)	4
7	CBH-1209	Ring – Retaining	1
8	CBH-1210	Washer – Bevel (1/2)	4
9	CBH-1211	Lockwasher (1/2)	4
10	CBH-1212	Nut – Hex (1/2-13)	4
11	CBH-1213	48" Gage	
	CBH-1214	66" Gage	
	CBH-1215	78" Gage	
		Assembly – Trolley Beam	1

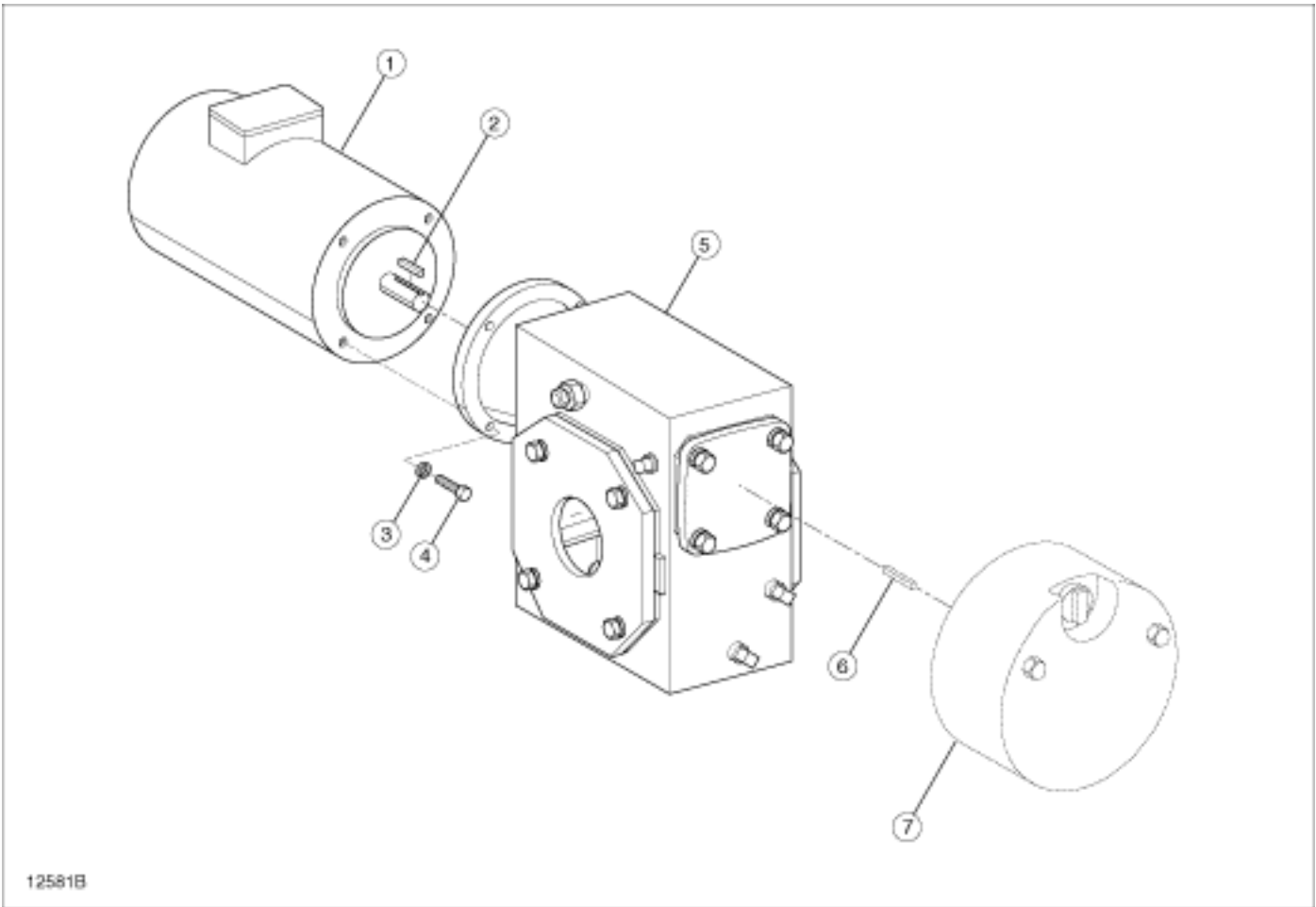

Figure 3. Motor and Gear Box Assembly.

Ref. No.	Key Number	Description	Qty. Req'd
1		Motor	1
	CBH-1360	Single Speed – .75 HP	
	CBH-1361	208-230/460 Volts, 3 Phase, 60 Hertz	
		575 Volts, 3 Phase, 60 Hertz	
		Two Speed – .75/.37 HP	
	CBH-1375	208 Volts, 3 Phase, 60 Hertz	
	CBH-1376	230 Volts, 3 Phase, 60 Hertz	
	CBH-1377	460 Volts, 3 Phase, 60 Hertz	
	CBH-1378	575 Volts, 3 Phase, 60 Hertz	
2	CBH-1366	Key – Motor (3/16 x 3/16 x 1-1/4)	1
3	CBH-1367	Lockwasher (3/8)	4
4	CBH-1368	Bolt – Hex Head (3/8-16 x 7/8)	4
5		Gear Box	1
	CBH-1369	Standard	
	CBH-1370	For Optional Brake	
6	CBH-1371	Key – Brake (Optional – 3/16 x 3/16 x 1-3/8)	1
7		Brake – Optional	1
	CBH-1372	208-230/460 Volts, 3 Phase, 60 Hertz	
	CBH-1373	575 Volts, 3 Phase, 60 Hertz	

ORDERING INSTRUCTIONS: Furnish complete data from motor and gear box nameplates with parts order. Replacement parts cannot be provided without this information.

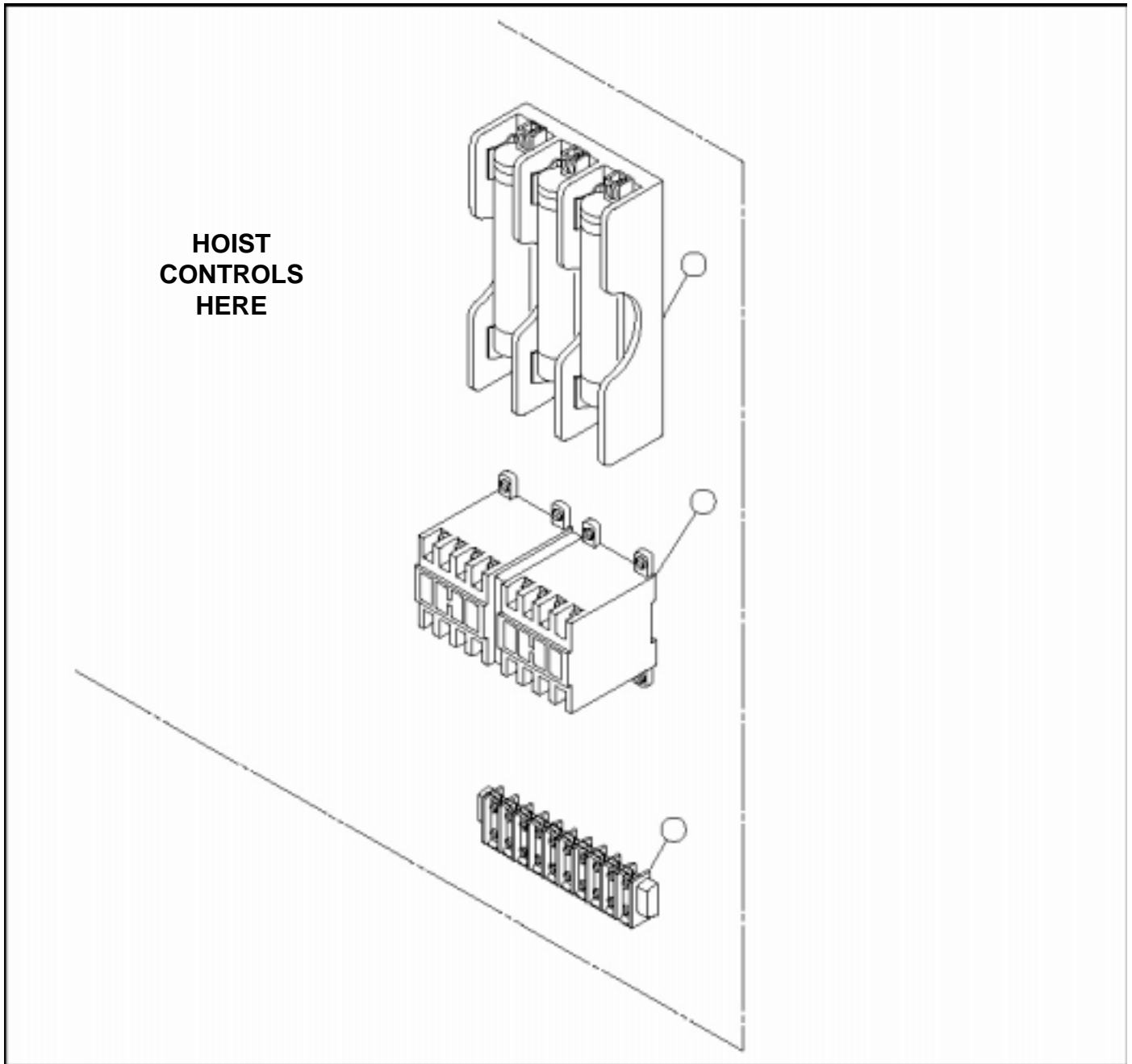

Figure 4. Traverse Controls for Single Speed Trolley.

Ref. No.	Key Number	Description	Qty. Req'd
1	CBH-1401	Traverse Motor Fuse (Optional)	1
	CBH-1402	208/230V	
	CBH-1403	460/575V	
	CBH-1404	Replacement Fuses	3
2	CBH-1410	Reversing Contactor	1
3	CBH-1411	Terminal Board	1
		The Following Items Are Not Shown:	
	CBH-1412	DIN Rail for Contactor Mounting	1
	CBH-1413	Slotted Round Head Screws for DIN Rail (#10 - 32 x 3/8)	3
	CBH-1414	Slotted Round Head Screws for Terminal Block (#8 - 32 x 5/8)	2

NOTE: When ordering contactor, specify voltage. Contactor must be replaced as a complete unit.

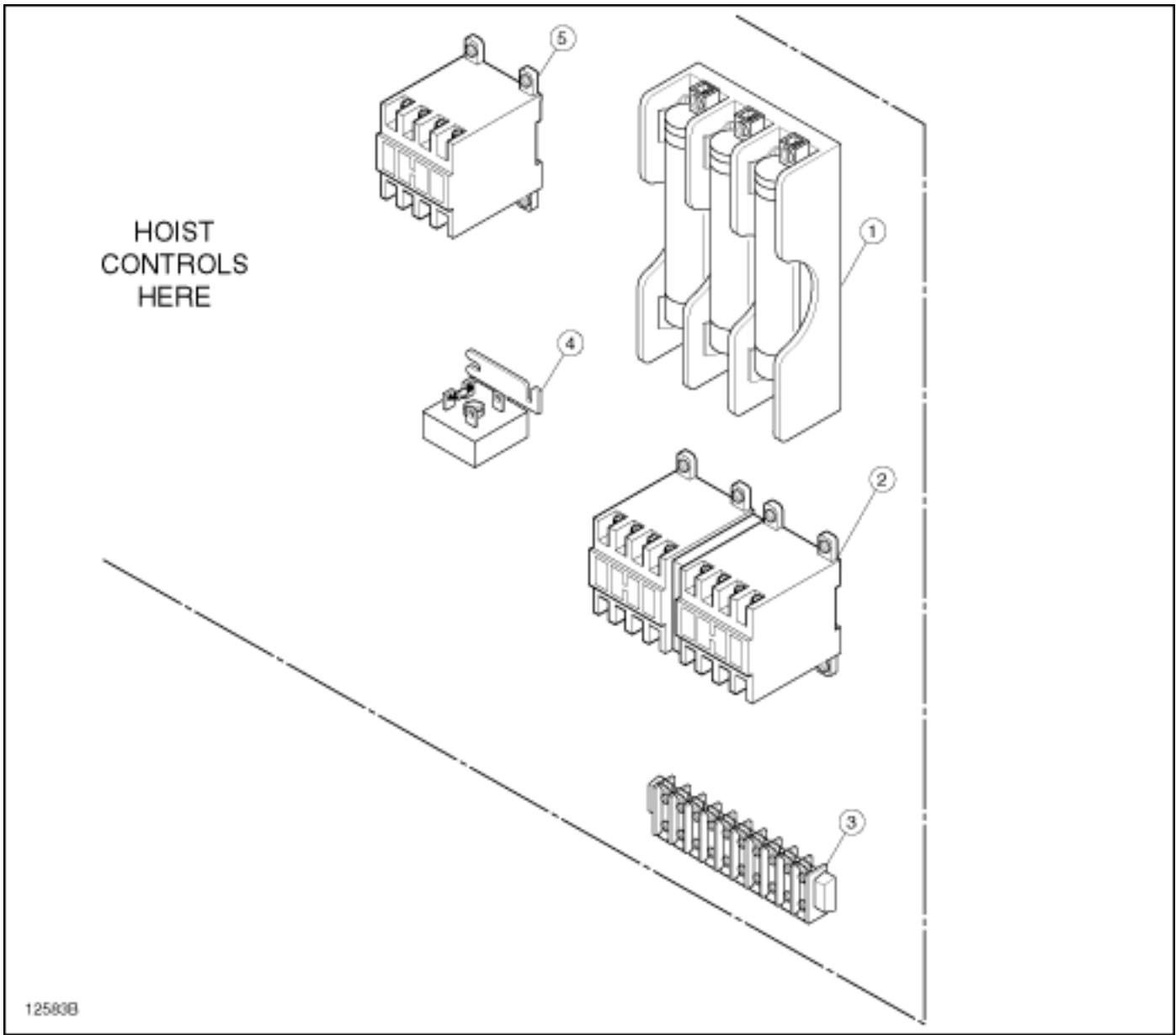

Figure 5. Traverse Controls for Two Speed Trolley.

Ref. No.	Part Number	Description	Qty. Req'd
1	CBH-1401 CBH-1402	Traverse Motor Fuse (Optional) 208/230V 460/575V	1
	CBH-1403 CBH-1404	Replacement Fuses 208/230V 460/575V	3
2	CBH-1410	Reversing Contactor	1
3	CBH-1411	Terminal Board	1
4	CBH-1511	Time Delay Relay	1
5	CBH-1512	Fast Contactor	1
		The Following Items Are Not Shown:	
	CBH-1412	DIN Rail for Contactor Mounting	1
	CBH-1413	Slotted Round Head Screws for DIN Rail (#10 - 32 x 3/8)	3
	CBH-1414	Slotted Round Head Screws for Terminal Block (#8 - 32 x 5/8)	2
	CBH-1513	Slotted Round Head Screws for Time Delay Relay (#8 - 32 x 7/8)	2

NOTE: When ordering contactors, specify voltage. Contactors must be replaced as a complete unit.

NOTES

Recommended Spare Parts for Your SHAW-BOX Traverse

Certain parts of your traverse will, in time, require replacement under normal wear conditions. It is suggested that the following parts be purchased for your traverse as spares for future use.

<u>Description</u>	<u>Quantity</u>
Contactors	1
Traverse Fuses (If Furnished)	3
Axle Bearings	4

NOTE: When ordering parts always furnish Catalog Number and Part Number.

Parts of your traverse are available from your local authorized SHAW-BOX repair station. For the location of your nearest repair station, write:

In USA

LIFT-TECH INTERNATIONAL, INC.
PO BOX 769
MUSKEGON MI 49443-0769

In Canada

Lift-Tech International
Cranes & Hoist, Inc.
53-D Cowansview Road
Cambridge, Ontario N1R 7L2

or phone:

616-733-0821

519-621-3201

WARRANTY

WARRANTY AND LIMITATION OF REMEDY AND LIABILITY

A. Seller warrants that its products and parts, when shipped, and its work (including installation, construction and start-up), when performed, will meet applicable specifications, will be of good quality and will be free from defects in material and workmanship. All claims for defective products or parts under this warranty must be made in writing immediately upon discovery and, in any event, within one (1) year from shipment of the applicable item unless Seller specifically assumes installation, construction or start-up responsibility. All claims for defective products or parts when Seller specifically assumes installation, construction or start-up responsibility, and all claims for defective work must be made in writing immediately upon discovery and, in any event, within one (1) year from completion of the applicable work by Seller, provided; however, all claims for defective products and parts must be made in writing no later than eighteen (18) months after shipment. Defective items must be held for Seller's inspection and returned to the original f.o.b. point upon request. THE FOREGOING IS EXPRESSLY IN LIEU OF ALL OTHER WARRANTIES WHATSOEVER, EXPRESS, IMPLIED AND STATUTORY, INCLUDING, WITHOUT LIMITATION, THE IMPLIED WARRANTIES OF MERCHANTABILITY AND FITNESS.

B. Upon Buyer's submission of a claim as provided above and its substantiation, Seller shall at its option either (i) repair or replace its product, part or work at either the original f.o.b. point of delivery or at Seller's authorized service station nearest Buyer or (ii) refund an equitable portion of the purchase price.

C. This warranty is contingent upon Buyer's proper maintenance and care of Seller's products, and does not extend to fair wear and tear. Seller reserves the right to void warranty in event of Buyer's use of inappropriate materials in the course of repair or maintenance, or if Seller's products have been dismantled prior to submission to Seller for warranty inspection.

D. The foregoing is Seller's only obligation and Buyer's exclusive remedy for breach of warranty, and is Buyer's exclusive remedy hereunder by way of breach of contract, tort, strict liability or otherwise. In no event shall Buyer be entitled to or Seller liable for incidental or consequential damages. Any action for breach of this agreement must be commenced within one (1) year after the cause of action has accrued.